

Mount Angle Plate as shown

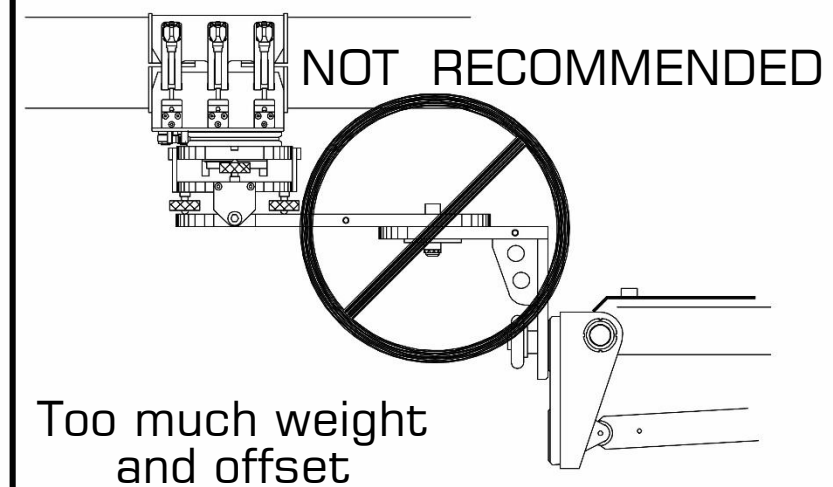

Too much weight and offset

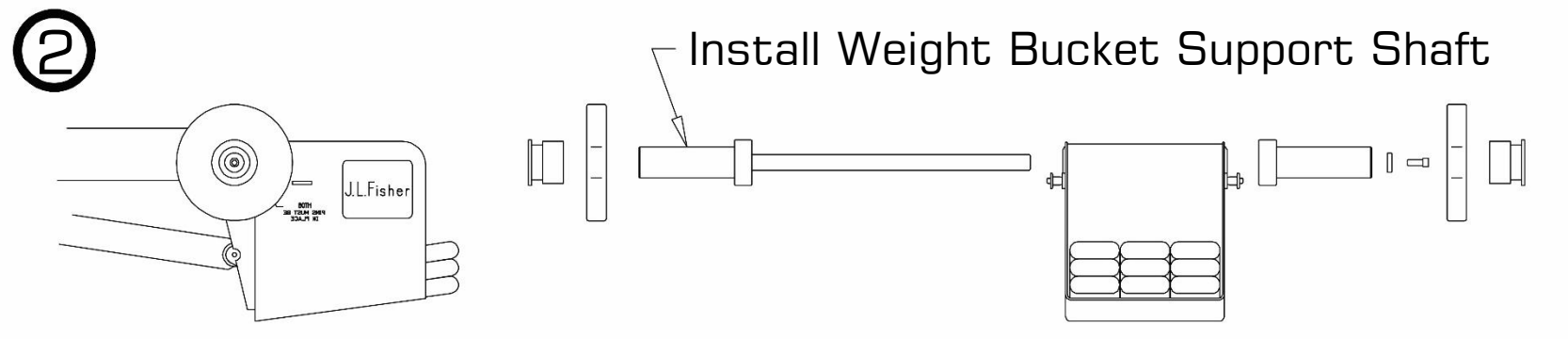

Place regular Jib Weights in Weight Bucket and Round Weights on Support Shaft as needed to balance Jib

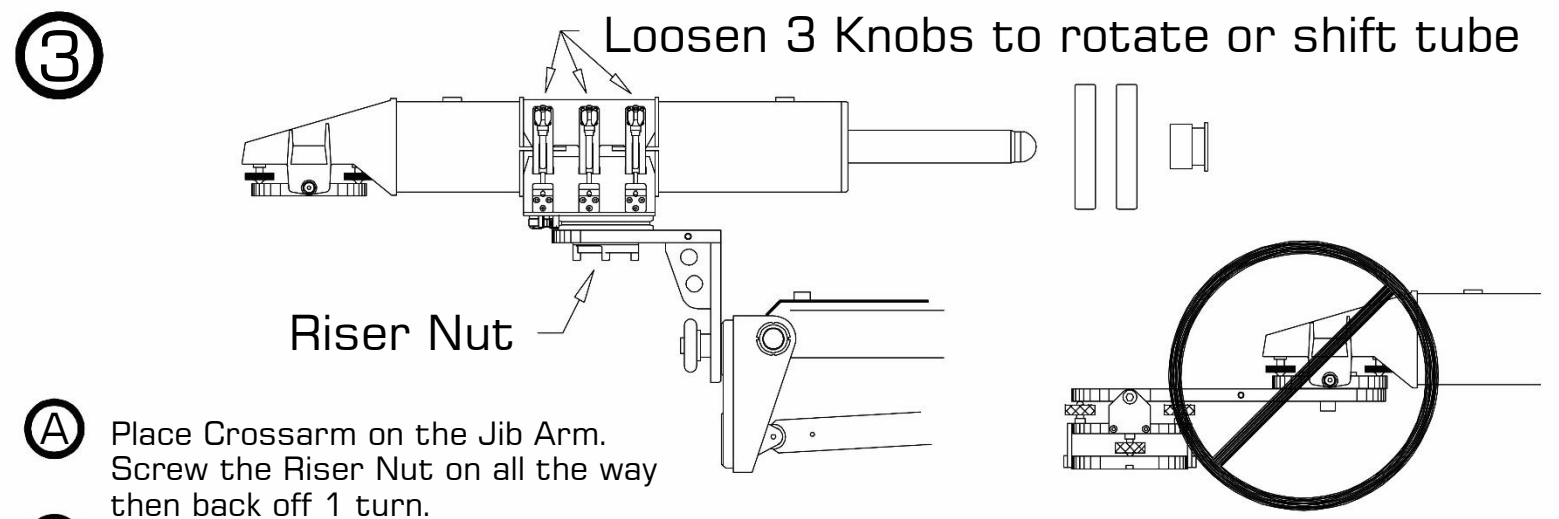

Riser Nut

No Extensions or Offsets

- A** Place Crossarm on the Jib Arm. Screw the Riser Nut on all the way then back off 1 turn.
- B** Loosen the three Knobs and shift or rotate the Tube to the desired position. Retighten Knobs evenly by hand only.
- C** Place two or three Round Weights on the tail of the Crossarm and more Weights in the Weight Bucket of the Jib to balance.
- D** Place Fluid Head and Camera on the Crossarm. Add additional Weights in the Weight Bucket to balance the Jib Arm.

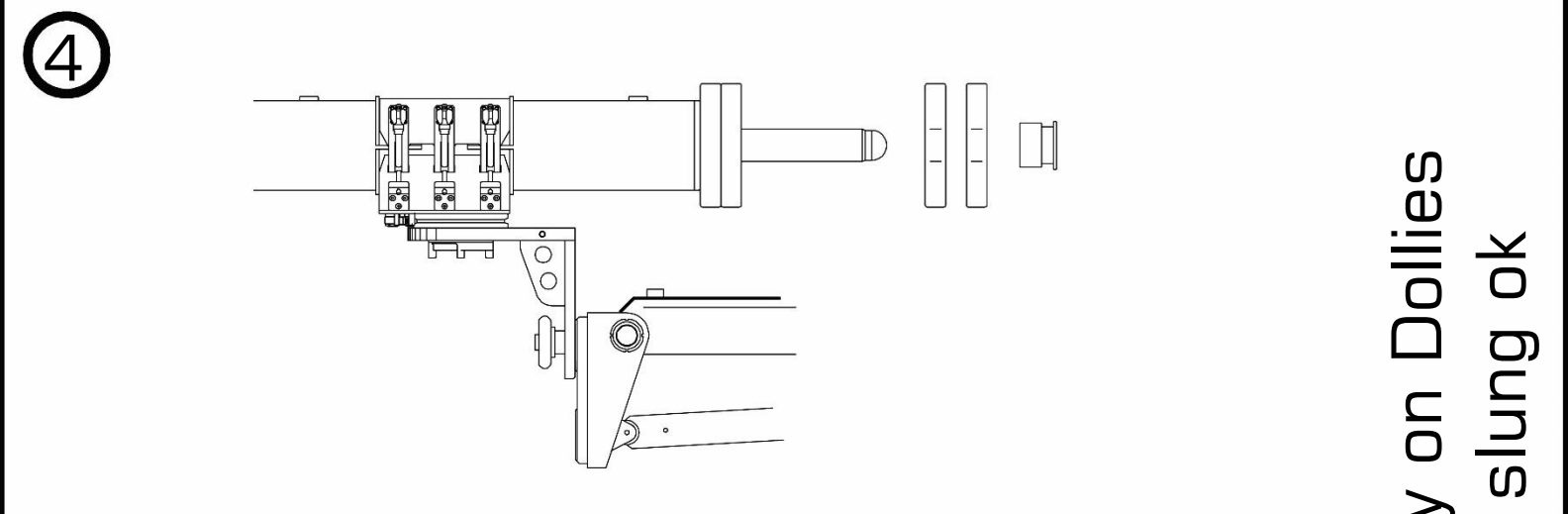

- E** The Riser Nut should be loose from step -A-, the Fluid Head, the Camera, and all its accessories are in place.
- F** Add additional Weights to the tail of the Crossarm. By rocking the Crossarm you will be able to Judge when balance has been achieved.
- G** Tighten Riser Nut. A block of wood and a hammer works well. - NEVER HIT RISER NUT DIRECTLY WITH HAMMER-
- H** Place Retaining Collar on tail of Crossarm, continue to fill the Weight Bucket until balance of Jib is achieved. Place Retaining Collar on both sides of the Weight Bucket.

Use directly on Dollies or under slung ok

Manufactured by the **JIMMY FISHER CO.** in North Hollywood, CA  
 Now property of J.L. Fisher Inc. at 1000 Isabel St. Burbank CA 818-846-8366

A\_main\_folder on 'Cad1' P:\1 Joe Jr. Doc\Crossarm.docx

# Instructions for suggested use with J.F.C. Model 20, 21, 22, & 23 Jib Arms