

J.L.Fisher

Motion Picture &  
Television Equipment

# MODEL 2 MICROPHONE BOOM MODEL 3 BASE

J.L. Fisher provides professionals in the motion picture, television and video industries worldwide with excellent products and services at a very reasonable price. Our reputation is the best in this industry and as the industry leader we are committed to our customers. With award-winning equipment, knowledgeable staff and a state of the art facility, quality is first and foremost at J.L. Fisher. We listen to our customers to gain insight about their needs and continually improve our products and services. Our reputation for unsurpassed reliability gives you peace of mind.



Manufactured from the highest quality materials and components to meet the demanding needs of the entertainment industry, these stable, reliable Microphone Booms offer operators a wide variety of accessories. They also incorporate many features and options suggested by our customers.

*J.L. Fisher booms are engineered and handcrafted to be the most reliable sound booms available and they have the lowest maintenance of any telescopic audio booms. Sound mixers and boom operators appreciate its outstanding dependability and ease of use... just ask them.*

# MODEL 2 MICROPHONE BOOM

The Model 2 is our smallest Microphone Boom. This telescopic Boom is quiet, smooth, safe and easy to use on location, feature films, television and video productions. The Model 2 Boom can be mounted overhead on Catwalk Stands (ACS, CS) or on stage flooring using the Model 3 Base (3) or in some cases the Model 6E Base (6E). The Model 2 Boom's compact size and features enable the boom operator to position the microphone in confined areas.

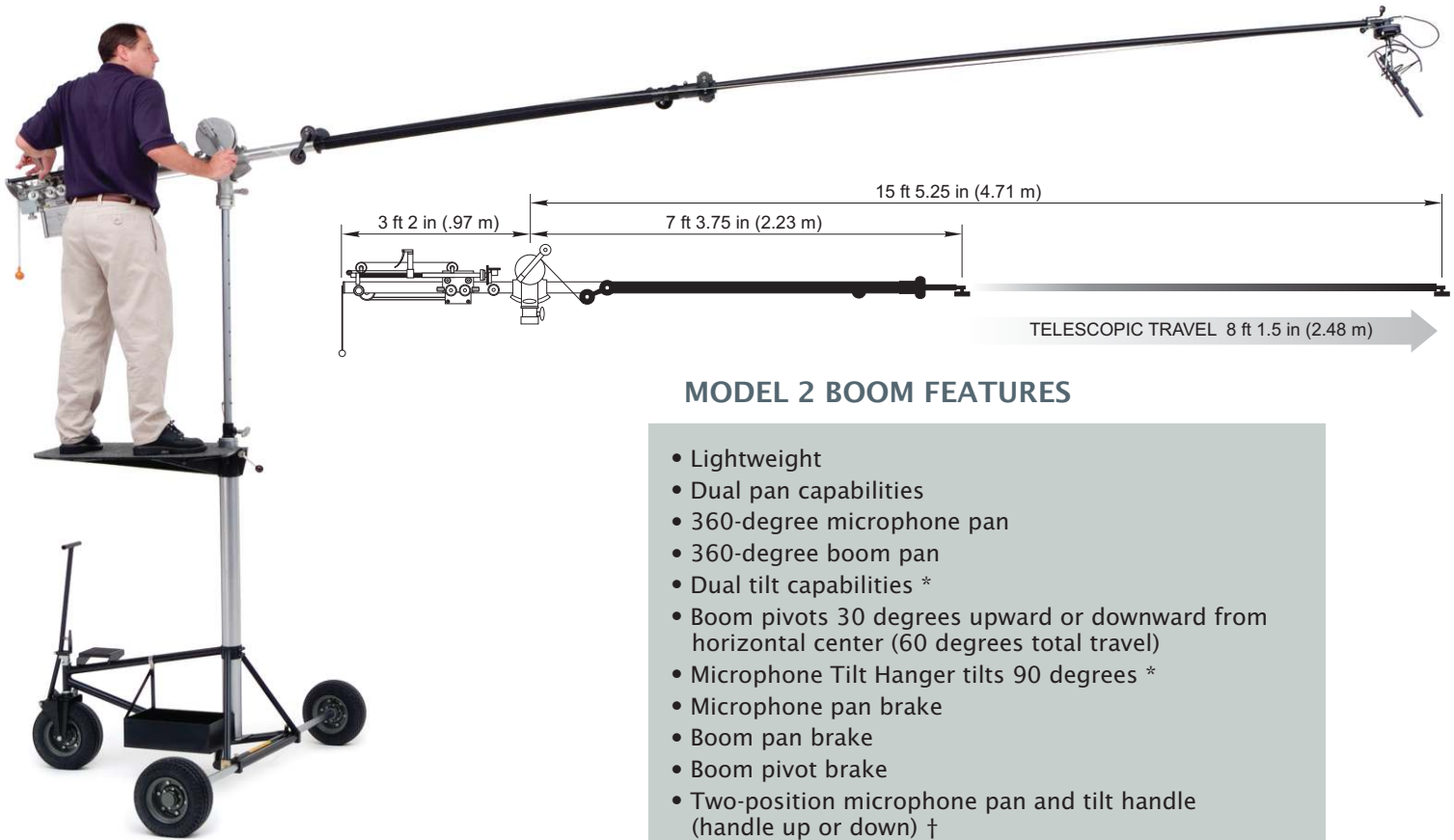

## MODEL 2 BOOM FEATURES

- Lightweight
- Dual pan capabilities
- 360-degree microphone pan
- 360-degree boom pan
- Dual tilt capabilities \*
- Boom pivots 30 degrees upward or downward from horizontal center (60 degrees total travel)
- Microphone Tilt Hanger tilts 90 degrees \*
- Microphone pan brake
- Boom pan brake
- Boom pivot brake
- Two-position microphone pan and tilt handle (handle up or down) †
- Adjustable panning handle †
- Continuous balance throughout telescopic range
- Adjustable counterbalance weights
- Accommodates microphones up to 4 pounds (1.8 kg)
- Industry standard mounting socket
- Precision concentrically ground polyurethane rollers
- Taper ground inside tube
- Sound dampening outside tube cover
- Short rear projection

\* For Booms with J.L. Fisher Tilt Hanger  
 † Not on Booms with Tilt Hanger



Shown with Monitor Tray (MT)  
and Script Rack (SR)

## MODEL 2 BOOM SPECIFICATIONS

|                             |                              |
|-----------------------------|------------------------------|
| Minimum length . . . . .    | 10 feet 7.5 inches (324 cm)  |
| Maximum length . . . . .    | 18 feet 9 inches (572 cm)    |
| Minimum reach . . . . .     | 7 feet 3.75 inches (223 cm)  |
| Maximum reach . . . . .     | 15 feet 5.25 inches (471 cm) |
| Maximum payload . . . . .   | 5 pounds (2.27 kg)           |
| Boom pivot . . . . .        | 60 degrees                   |
| Boom pan . . . . .          | 360 degrees                  |
| Telescopic travel . . . . . | 8 feet 1.5 inches (248 cm)   |
| Rear projection . . . . .   | 38 inches (97 cm)            |
| Maximum Payload . . . . .   | 4 pounds (1.8 kg)            |
| Weight . . . . .            | 31 pounds (14.13 kg)         |

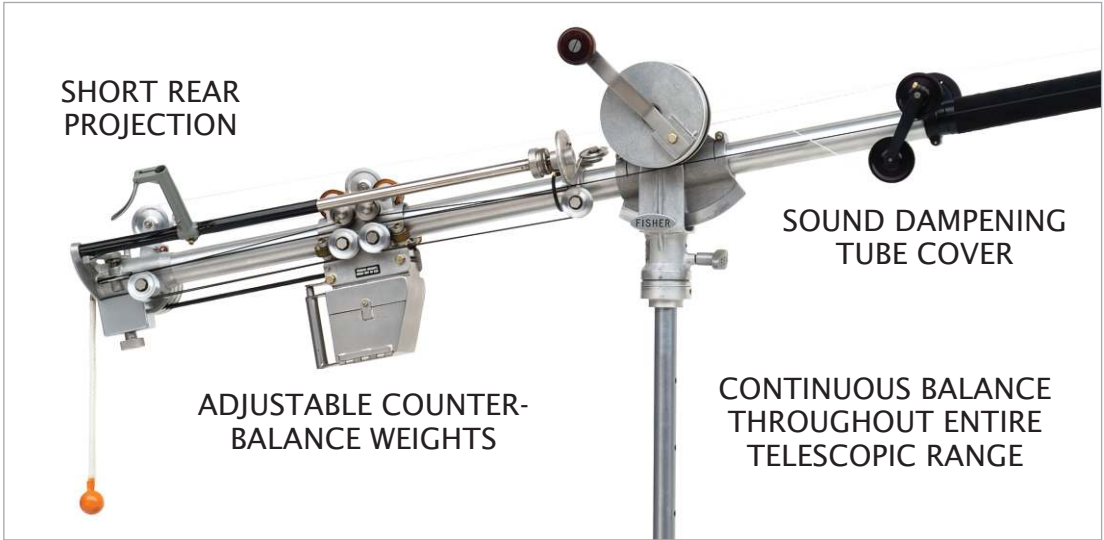

## MODEL 3 BASE

The Model 3 is our smallest Base. It is for use with the Model 2 Boom only. The Model 3 is lightweight, safe and easy to operate. It is ideally suited for use on location, small stages and confined areas.

### MODEL 3 BASE FEATURES

- Lightweight
- Adjustable boom height
- Adjustable platform height
- Extendable locking axles
- Air cushioned column for safety
- Attached weight and accessory box
- Pneumatic tires
- Positive locking brake system
- Single wheel steering
- Industry standard boom mount provides 360 degrees of Boom operation
- Platform extension for operator convenience and safety



POSITIVE LOCKING BRAKE



# OPTIONAL ACCESSORIES

- MC2 Audio Cable, 30-Foot (914.40 cm)
- CS Catwalk Stand
- HE3 Hanger Extension, 3 Inch (7.62 cm)
- HE6 Hanger Extension, 6 Inch (15.24 cm)
- HE12 Hanger Extension, 12 Inch (30.48 cm)
- HE18 Hanger Extension, 18 Inch (45.72 cm)
- MH Microphone Hanger with Two-Diameter Microphone Holder
- MT Monitor Tray
- MTB Monitor Tray Drop Down Bracket
- SR Script Rack
- TILT2 Tilt Mechanism with Two-Diameter (3/4 in or 1 in) Microphone Holder



Microphone Hanger (MH)

Hanger Extensions (HE)



Audio Cable (MC2)



Monitor Tray (MT)

Monitor Tray Drop Down Bracket (MTB)



Script Rack (SR)



Catwalk Stand (CS)

## MODEL 3 BASE SPECIFICATIONS

- Minimum width (wheels in) . . . . . 29 inches (74 cm)
- Maximum width (wheels out) . . . 58.75 inches (149 cm)
- Length . . . . . 51.5 inches (131 cm)
- Minimum Boom mount height . . . 66 inches (168 cm)
- Maximum Boom mount height . . 106 inches (269 cm)
- Minimum platform height. . . . . 28.5 inches (72 cm)
- Maximum platform height . . . . . 48 inches (122 cm)
- Column travel . . . . . 40 inches (102 cm)
- Platform travel. . . . . 28.5 inches (72 cm)
- Weight. . . . . 120 pounds (54.43 kg)

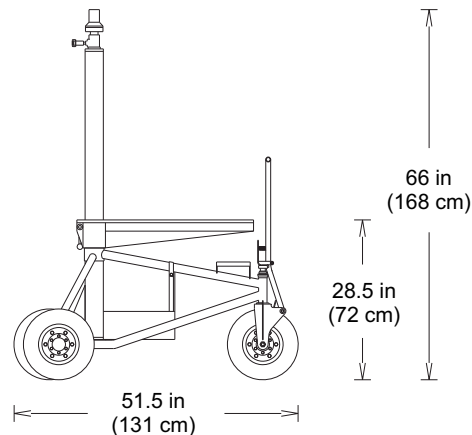
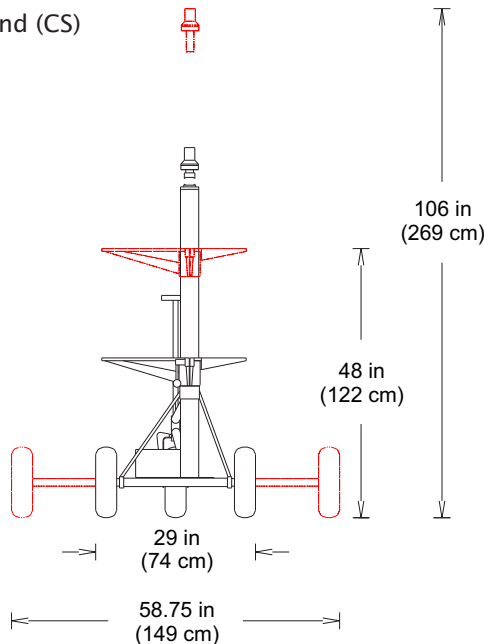

**J.L. FISHER PRODUCTS ARE PROUDLY MADE IN BURBANK, CALIFORNIA U.S.A.**

**J.L. Fisher, Inc. Motion Picture & Television Equipment**  
 1000 Isabel Street, Burbank, CA 91506 U.S.A.  
 Tel: (818) 846-8366 / Fax: (818) 846-8699  
 Web: [www.jlfisher.com](http://www.jlfisher.com) e-mail: [info@jlfisher.com](mailto:info@jlfisher.com)

**J.L. Fisher, GmbH Emil-Hoffmann-Str. 55-59 50996 Köln, Germany**  
 Tel: +49 2236 3922 0 Fax: +49 2236 3922 12  
 Web: [www.jlfisher.de](http://www.jlfisher.de) e-mail: [info@jlfisher.de](mailto:info@jlfisher.de)